

Washes 30 x 200 ml glasses
in 30 seconds!

SSS-30/30



COMMERCIAL GLASS WASHER



Sharpline 

Australian made – Australian owned

COMMERCIAL GLASS WASHER

SSS-30/30



The Sharpline SSS-30/30 Commercial Glass Washer is a fully automatic machine with the ability to wash 30 x 200 ml glasses every 30 seconds.

Features of the SSS-30/30 include:

Wash Cycle: hot wash with a hot rinse.

An additional cold rinse can be selected after the hot rinse at the flick of a switch.

A large door opening enables the machine to wash tall glasses.

Hot water that is internally boosted by a 3300 watt element and thermostatically controlled to 82°C.

Fully automatic detergent dispenser integrated in wash cycle.

Basket size is 445 mm x 365 mm and will hold 30 x 200 ml glasses or 24 x 285 ml glasses.

The SSS-30/30 is suitable for under counter or freestanding installation.

High performance pump ensures constant water pressure.

Electrical requirement:
Provide 15 amp single phase outlet.

*For further information visit our web site!
www.sharpline.com.au*

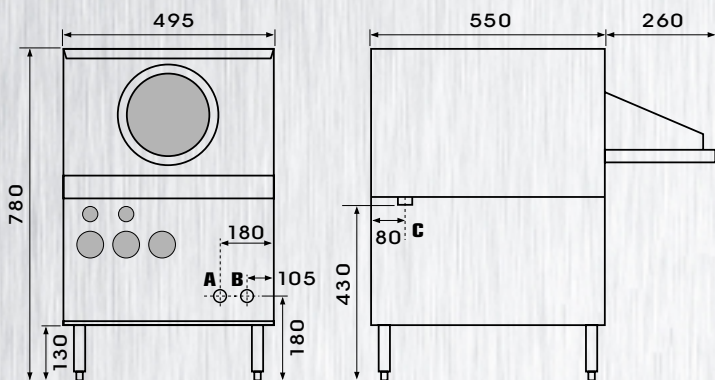

Connection Points

- A** Hot Water 3/4" B.S.P.
- B** Cold Water 3/4" B.S.P.
Flexibe hoses supplied for hot and cold water
- C** Drain 50 mm B.S.P.
* Provide 15 Amp Power Point

Sharpline

Australian made – Australian owned

700 Sydney Road (Cnr Gaffney Street)
Coburg Victoria Australia 3058
Phone 03 9354 0277 Fax 03 9354 0278
Email: sharpline@sharpline.com.au
www.sharpline.com.au

STAINLESS STEEL PTY LTD

ABN 95 880 037 140

Specifications subject to change without notice

Design/Production: Roman Zylinski advertising Services. 03 9561 9957. roman.zylinski@bigpond.com