

NORRIS E17 GLASSMATE ELITE SERIES II

High performance glasswasher with cold final rinse option

Australia's Number One Glasswasher:

The E17 Glasswasher has been Australia's number one selling glasswasher for over 40 years. With the release of the new Elite Series II Glassmate now rated 15 amps, for increased output, Norris has ensured that the E17 will remain the number one choice for many years to come.



Suitable for Low Water Pressure Areas:

The E17 is fitted with our exclusive triarm rotary spinner, automatic detergent injection and a powerful 373W Wash/Rinse pump. This ensures that even the dirtiest glasses will come out sparkling clean regardless of incoming water pressure. The automatic detergent injection has an external adjustment to allow the operator to compensate for different detergents and water quality.

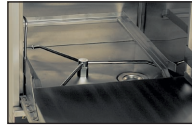

High Performance:

Now rated 15 amps, the E17 is capable of processing up to 1800* glasses per hour. The machine is equipped with a selectable, cold cooling down rinse cycle, which is designed to lower the temperature of the glasses after the hot rinse allowing a faster turnaround.



Fast Recovery:

Hot Water is delivered by the inbuilt hot water booster tank, which incorporates low water level protection and a 3kW element for faster recovery. The tank is fully sealed so in the event of a valve failure, excess water is directed down the drain rather than flooding the premises. This allows the glasswasher to be built into a confined space or under timber bars, as there is no water condensation released from the rear of the machine.

Conformance to Regulations:

An internal interlock will prevent the machine from operating unless the temperature required by regulation has been reached. A clearly legible wash/rinse water temperature gauge allows the operator to confirm that the machine is operating within the prescribed range.

The E17 Glassmate is approved for direct connection to the water supply without any further backflow protection.



Simple Controls:

The E17 Glassmate is simple to operate. Slide the tray the machine and close the door. When the green light is illuminated push the start button and 30 seconds later you will have sparkling clean glasses. A door safety switch cuts the cycle if someone attempts to open the door while a cycle is in progress.

Durability:

Norris machines have always been known for their strength and reliability. With The Elite series E17 the standards have been set even higher. The insulated door has a fully sealed clean inner skin for added strength and ease of cleaning. So confident are we at Norris in the strength of the machine that we offer a five-year warranty on the cabinet including the door.

Designed for the Australian Market:

Norris has deliberately refrained from using electronics in their machines. All controls are electromechanical and are readily available, this ensures that should your machine ever need servicing a local tradesperson will be able to get you up and running with minimum disruption and cost.

* Dependant on incoming hot water temperatures

** For pressures above 400kPa a pressure-limiting valve must be used

Norris machines are supported by a nationwide network of service agents.

Dimensions	
Height Cabinet inc Legs	850-875mm
Height Cabinet Only	700mm
Leg Height	150-175mm
Width	505mm
Depth	545mm
Depth with Door Open	820mm
Load Height	400mm
Usable Wash Height	250mm
Basket Supplied	1 x 430mm x 360mm
Capacity	
Loads per Hour	60*
Wash/Rinse Pump	373W
Rinse Tank Capacity	20L
Rinse Tank Element	3000W
Wash Temperature	82-88°C
Rinse Temperature	82-88°C
Detergent Injection	10-20ml/cycle
Total Cycle Time	30 sec
Wash Cycle Time	5 sec
Rinse Cycle Time	10+15 Either Hot or Cold
Hot Water Usage per cycle	
Hot/Cold Cycle:	4 Litres
Hot/Hot Cycle:	8 Litres
Plumbing Connections	
Hot Water	15mm BSP
Cold Water	15mm BSP
Waste	50mm BSP
Water Pressure	140-400 Pa**
Electrical	
Volts/Hz/Amps	230V AC 50 Hz 15amp

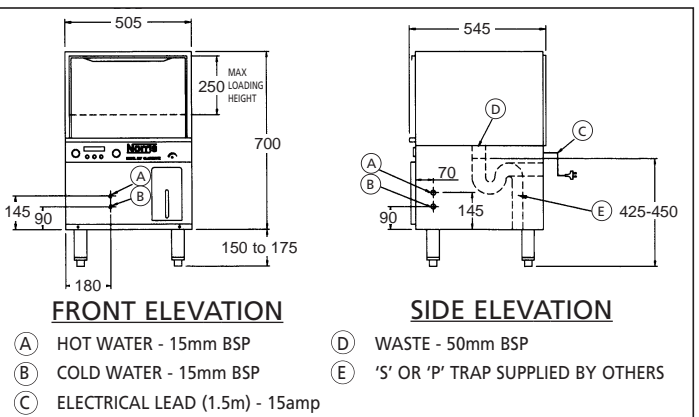

Norris Industries Pty Ltd

ABN 69 002 351 840

28 Strathmore Road, Caves Beach.NSW 2281

Telephone (02) 4971 4500. Facsimile (02) 4972 1064

www.norris.com.au



YOUR NORRIS DISTRIBUTOR: